

Aquasonic®

MULTICLIMATE AIRSPEAKERS

Aguaceiro™

The Aguaceiro™ MultiClimate Airspeaker is more than water resistant—it's weatherproof in any environment! The blistering heat of the Arizona desert, a frigid outdoor terrace at a Swiss ski resort, seaspray at a beachfront condo in the Mediterranean, drenching rain in any region, your backyard—you name it, the Aguaceiro™ can handle anything that comes its way.

Experience superb sound in your outdoor living area with the Aguaceiro™ MultiClimate Airspeaker. The Aguaceiro™ is the most durable outdoor speaker available today, and it is designed to blend in to its surroundings. Clark Synthesis is so sure of the performance of the new Aguaceiro™, it comes with a limited lifetime warranty. This hardy all weather speaker comes ready to install with a weatherproof screen and mounting bracket.

Why buy an outdoor speaker you'll have to replace in a few years when you can enjoy the Aguaceiro™ for life?

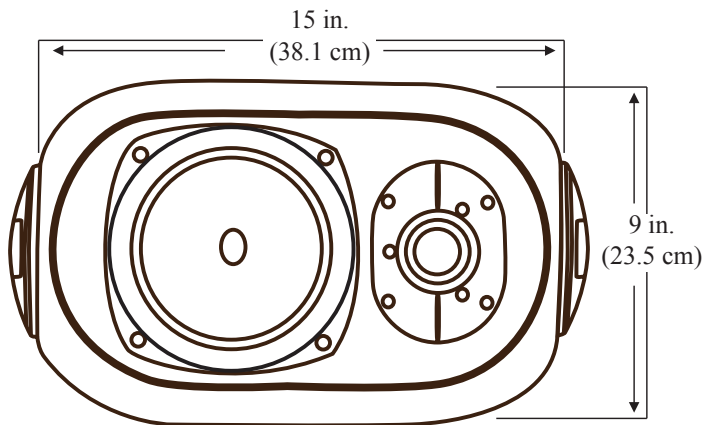

**The Aguaceiro™ comes with 4 ft. of weatherproof cable and is preassembled with protective screen and mounting bracket.*



- Specifications:** Frequency Response: 75 Hz to 20 KHz * Power Handling: 100 Watts Continuous
* Impedance: 8 Ohms * Dimensions: 15" (38.1cm) x 9.25" (23.5cm) x 8.5" (21.6cm) * Weight: 12 lbs (5.4 kg)
* Recommended Amplification: 125 watts at 8 ohms



CLARKSYNTHESIS

Tel: 303-797-7500 Fax: 303-797-7501
www.clarksynthesis.com

Aquasonic®

MULTICLIMATE AIRSPEAKERS

Aguaceiro™

The Aguaceiro™ MultiClimate Airspeaker is more than water resistant—it's weatherproof in any environment! The blistering heat of the Arizona desert, a frigid outdoor terrace at a Swiss ski resort, seaspray at a beachfront condo in the Mediterranean, drenching rain in any region, your backyard—you name it, the Aguaceiro™ can handle anything that comes its way.

Experience superb sound in your outdoor living area with the Aguaceiro™ MultiClimate Airspeaker. The Aguaceiro™ is the most durable outdoor speaker available today, and it is designed to blend in to its surroundings. Clark Synthesis is so sure of the performance of the new Aguaceiro™, it comes with a limited lifetime warranty. This hardy all weather speaker comes ready to install with a weatherproof screen and mounting bracket.

Why buy an outdoor speaker you'll have to replace in a few years when you can enjoy the Aguaceiro™ for life?

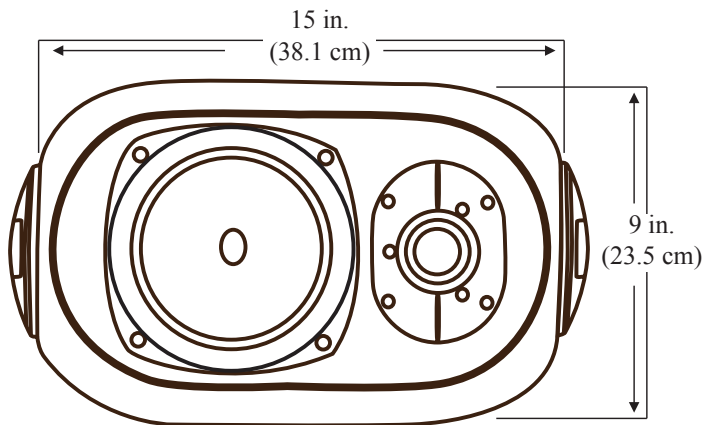

**The Aguaceiro™ comes with 4 ft. of weatherproof cable and is preassembled with protective screen and mounting bracket.*



- Specifications:** Frequency Response: 75 Hz to 20 KHz * Power Handling: 100 Watts Continuous
* Impedance: 8 Ohms * Dimensions: 15" (38.1cm) x 9.25" (23.5cm) x 8.5" (21.6cm) * Weight: 12 lbs (5.4 kg)
* Recommended Amplification: 125 watts at 8 ohms



CLARKSYNTHESIS

Tel: 303-797-7500 Fax: 303-797-7501
www.clarksynthesis.com

AW339 ALL-WEATHER

The AW339 All-Weather Transducer is the weather-resistant version of the TST329 Gold. Specifically designed to withstand rain and humidity, the AW339 can handle many adverse conditions that would damage ordinary speakers or transducers. The AW329 can turn a deck, hot tub, or boat hull into a full-frequency speaker, and produce full-fidelity sound in a variety of climates and environments.



Originally developed for military and commercial training simulators, Full Contact Audio® transducers were specifically designed to transfer sounds like gunshots and explosions into a tactile experience that can be felt as well as heard.

The AW339 All-Weather Transducer requires an amplifier for operation. Clark Synthesis recommends using an amplifier stable at 4 ohms that can deliver 125-150 watts @ 4 ohms (per transducer).

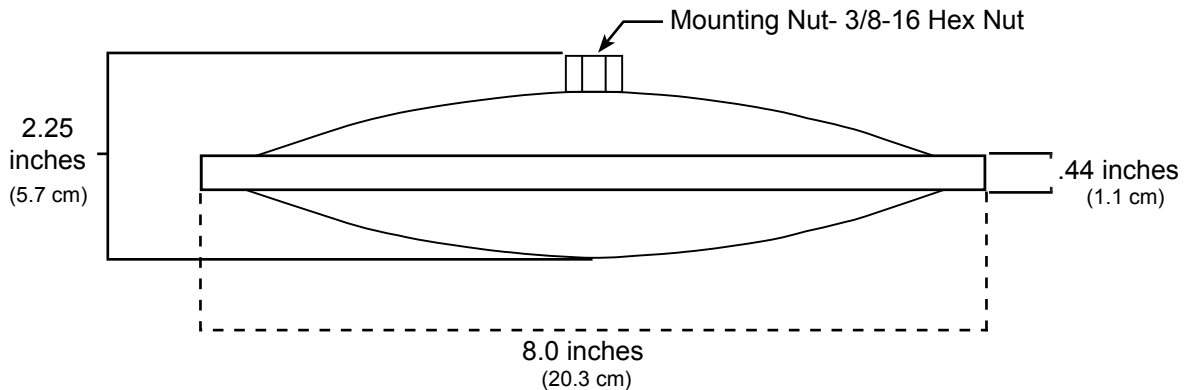

AW339 Specifications: • Continuous power handling: 135 watts • Impedance: 4 ohms • Overload Protection: Polyswitch • Frequency Response: 10Hz to 17kHz • Electrical Connection: 3ft. - 16 guage, 2 wire • Dimensions: 8 in. diam. x 2.25 in. high • Recommended Amplification: 125 - 150 watts at 4 ohms



Aquasonic®

UNDERWATER LOUDSPEAKERS

Diluvio™

The Diluvio™ Underwater Loudspeaker is the world's only full-frequency, full-fidelity underwater loudspeaker. Backyard pool enthusiasts, lap swimmers and competitive swimmers agree the Diluvio™ turns any pool experience into something truly spectacular. The Diluvio™ brings water to life, allowing music and sound to be heard through the body below the water's surface.

The Diluvio™ can be used in two different ways. For a permanent installation, the Diluvio™ can be mounted inside a large light niche with a face ring kit (sold separately). For users who require underwater sound in multiple locations, such as synchronized swim teams, a tether can be attached to the Diluvio™ so it can be used as a drop-in speaker.



The Diluvio™ Underwater Loudspeaker requires an amplifier for operation. Clark Synthesis recommends an amplifier stable at 4 ohms that can deliver 125-150 watts @ 4 ohms (per speaker).



**The Diluvio™ pictured in a third-party light niche and face ring kit. Niche and face ring kit sold separately.*

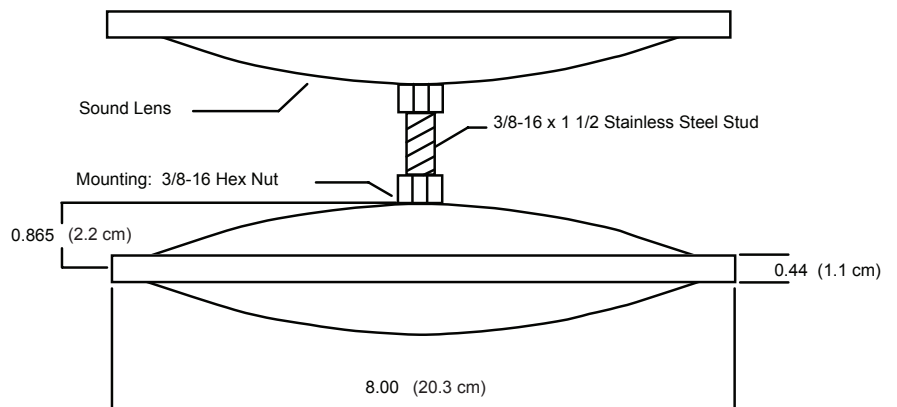

Specifications: • Continuous Power Handling: 135 watts • Impedance: 4 ohms • Overload Protection: Polyswitch • Frequency Response: 20Hz to 17kHz • Electrical Connection: 100ft. - Underwater, 16-2 Wire • Dimensions: 8" (20.3cm) Dia. x 4.5" (11.5cm) Deep • Recommended Amplification: 125 - 150 W at 4 Ohms



CLARKSYNTHESIS

Tel: 1-877-252-7544 Fax: 303-797-7501
www.clarksynthesis.com

CLARK SYNTHESIS IS THE
OFFICIAL SOUND SYSTEM SUPPLIER FOR
UNITED STATES SYNCHRONIZED SWIMMING



Isolation Transformer

The Aquasonic® Isolation Transformer is expertly designed for use when a no-conduction connection is required between an underwater speaker and the audio amplifier.

The Clark Synthesis Isolation Transformer is 96% efficient and is designed for use with our Aquasonic® Diluvio™ Underwater Loudspeaker. It is acoustically transparent and housed in a moisture-resistant enclosure that has built-in mounting tabs attached.

The Clark Synthesis Isolation Transformer comes installed with two Neutrik® Speakon® connectors (not cheap substitutes) and includes two Neutrik® Speakon® connectors for easy connection to amplifier and speaker wiring.



Isolation transformer with two speakon connectors.

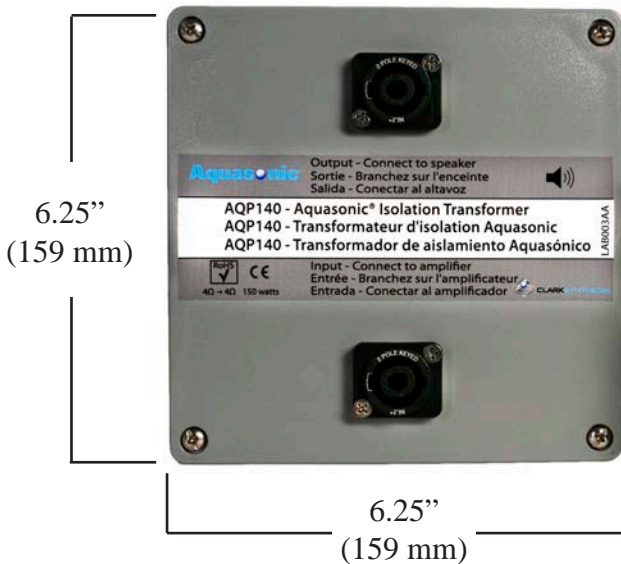

Back side - with mounting tabs.

Specifications: 6.25" (159 mm) W x 6.25" (159 mm) D x 4.375" (112 mm) H * 5.7 lbs (2.6 kg)

PROSOUND429 PACKAGE

The ProSound429 Platinum Thumper is the most powerful thumper available from Clark Synthesis. It is the first choice for many professional touring musicians. The ProSound429 Package includes: (1) ProSound429 Platinum Thumper (1) TC-101 Amplifier Interface with (2) Speak-on Connectors, (1) Gig Bag, and all the hardware for mounting the thumper to a drum throne, platform or staging.



Originally developed for military simulation devices, the Full Contact Audio[®] Professional Transducers were specifically designed to transfer sounds like gunshots and explosions into a tactile experience that can be felt as well as heard. This technology transferred to the music industry, and every knowledgeable drummer or sound stage touring manager will choose Clark Synthesis Professional Transducers over any other option due to their amazing performance quality and reliability. The TC-101 serves as a protection device to limit peak signals.

The ProSound429 Platinum requires an amplifier for operation. Clark Synthesis recommends an amplifier stable at 4 ohms that can deliver 125-150 watts @ 4 ohms (per transducer).

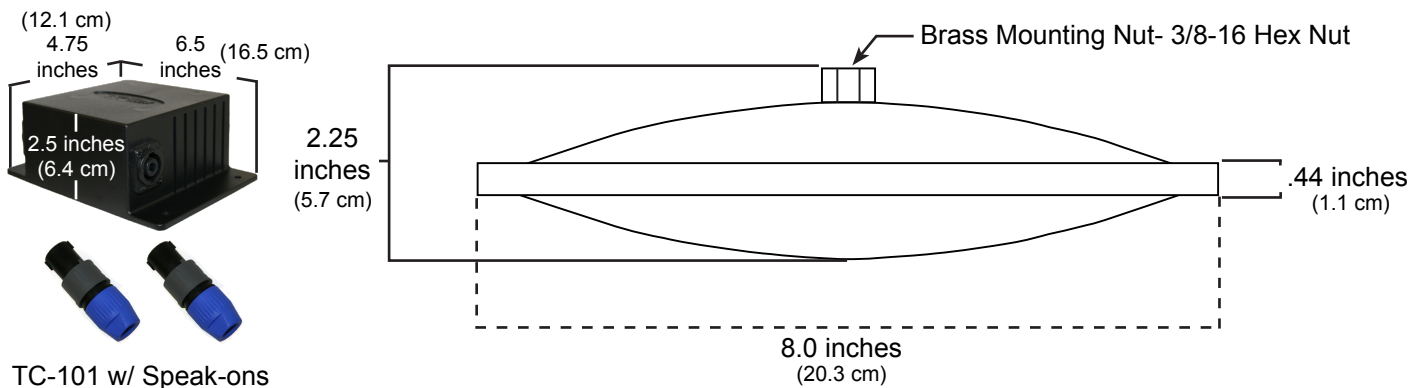

- Prosound429 Specifications:**
- Continuous power handling: 135 watts
 - Impedance: 4 ohms
 - Overload Protection: Polyswitch
 - Frequency Response: 5Hz to 17kHz
 - Electrical Connection: 3ft. - 16 gauge, 2 wire
 - Dimensions: 8 in. diam. x 2.25 in. high
 - Recommended Amplification: 125 - 150 watts at 4 ohms
 - The Prosound429 is not approved for vertical mounting.



TST239 SILVER

The TST239 Silver Transducer is an excellent choice for most entry-level audio applications. This product is widely used in the game chair market, providing solid performance at an affordable price. The TST239 Silver can be used in some home theater applications.

Originally developed for military and commercial training simulators, Full Contact Audio® transducers were specifically designed to transfer sounds like gunshots and explosions into a tactile experience that can be felt as well as heard. This technology was enthusiastically received by the video gaming community. Gamers of all ages love the intensified sensory experience of competing in a gaming chair with a Clark Synthesis transducer.

The TST239 Silver requires an amplifier for operation. Clark Synthesis recommends an amplifier stable at 4 ohms that can deliver 75-100 watts @ 4 ohms (per transducer).

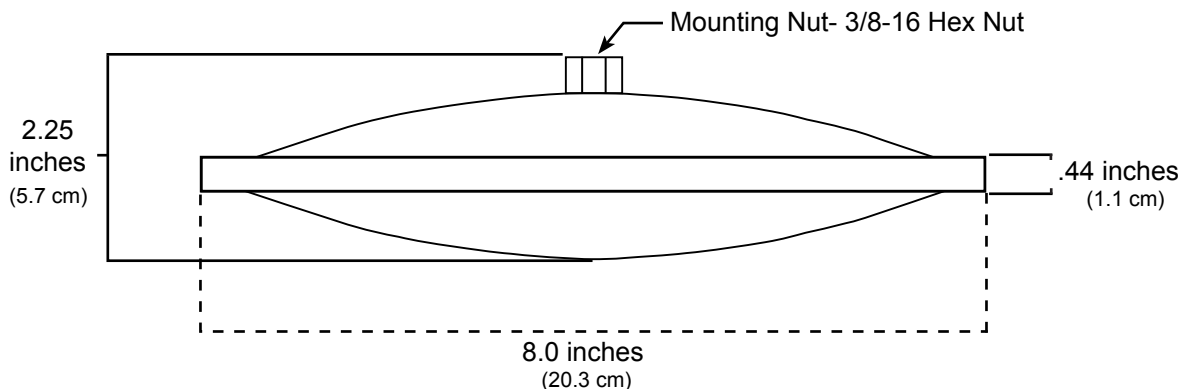

TST239 Specifications: • Continuous power handling: 100 watts • Impedance: 4 ohms • Overload Protection: Polyswitch • Frequency Response: 15Hz to 17kHz • Electrical Connection: 3ft. - 16 gauge, 2 wire • Dimensions: 8 in. diam. x 2.25 in. high • Recommended Amplification: 75 - 100 watts at 4 ohms • The TST239 is not approved for vertical mounting.



TST329 GOLD

The TST329 Gold Transducer has a proven record of superb performance, sound fidelity and efficiency. Available only from Clark Synthesis, the TST329 is one of our ProSound products and provides superb, reliable performance. The Gold Professional Transducer is a great choice in many audio/video applications such home theater furniture and commercial/military vehicle simulators.



Originally developed for military and commercial training simulators, Full Contact Audio® transducers were specifically designed to transfer sounds like gunshots and explosions into a tactile experience that can be felt as well as heard.

The TST329 Gold requires an amplifier for operation. Clark Synthesis recommends an amplifier stable at 4 ohms that can deliver 135 watts @ 4 ohms (per transducer).

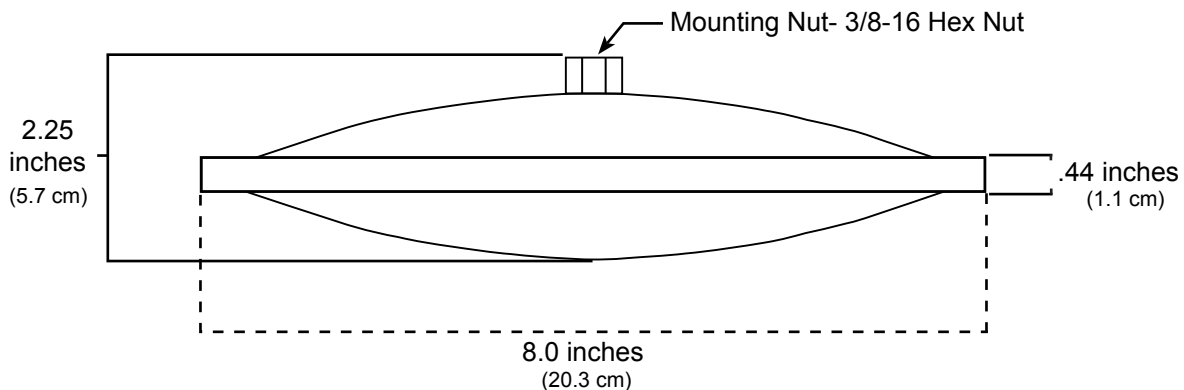

TST329 Specifications: • Continuous power handling: 135 watts • Impedance: 4 ohms • Overload Protection: Polyswitch • Frequency Response: 10Hz to 17kHz • Electrical Connection: 3ft. - 16 gauge, 2 wire • Dimensions: 8 in. diam. x 2.25 in. high • Recommended Amplification: 125 - 150 watts at 4 ohms • The TST329 is not approved for vertical mounting.



TST429 PLATINUM

The TST429 Platinum Professional Transducer is the most powerful audio transducer on the market today. Available only from Clark Synthesis, the TST429 provides the ultimate performance and output of full-fidelity, full-frequency sound with a frequency response from 5hz to 17kHz. This premium transducer is designed to meet the demands of audio applications such as high-end home theater furniture, theater risers and platforms, floors (including dance floors), simulators, gaming systems, and ProSound equipment.



Originally developed for military and commercial training simulators, Full Contact Audio® transducers were specifically designed to transfer sounds like gunshots and explosions into a tactile experience that can be felt as well as heard. The enhanced neodymium magnetic structure of a Platinum Transducer produces approximately twice the output of the popular TST329 Gold Professional Transducer. The extended frequency response and superior fidelity adds a new level of realism to every experience.

The TST429 Platinum requires an amplifier for operation. Clark Synthesis recommends an amplifier stable at 4 ohms that can deliver 125-150 watts @ 4 ohms (per transducer).

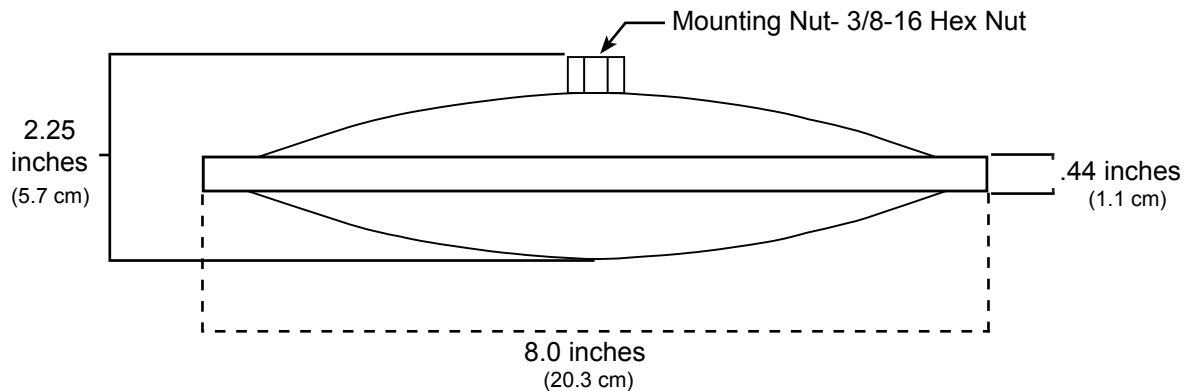

- TST429 Specifications:**
- Continuous power handling: 135 watts
 - Impedance: 4 ohms
 - Overload Protection: Polyswitch
 - Frequency Response: 5Hz to 17kHz
 - Electrical Connection: 3ft. - 16 gauge, 2 wire
 - Dimensions: 8 in. diam. x 2.25 in. high
 - Recommended Amplification: 125 - 150 watts at 4 ohms
 - The TST429 is not approved for vertical mounting.

